

# MADISON PARK® ASSEMBLY INSTRUCTIONS

## Description: Kirtley Writing Desk





### Important safety instructions:

- Please carefully read all instructions before assembling.
- For your safety and ease, assembly by two or more adults is recommended.
- Keep instructions for future use.



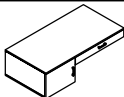

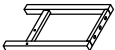
### Pre-assembly:

- Do not discard any contents until after assembly is complete to avoid accidentally discarding small parts or hardware.
- Remove all parts and hardware from box along with any plastic protective packaging.

### Parts List

Item	Description	QTY
P1	Table Top 	1
P2	Short Frame Leg 	1
P3	Long Frame Leg 	1
P4	Short Stretcher 	1
P5	Long Stretcher 	1

### Hardware List



Item	Description	QTY
H1	Bolts Ø5/16"×1-1/2" 	10
H2	Lock Washer Ø5/16" 	10
H3	Flat Washer Ø5/16"×3/4" 	10
H4	Allen Wrench 4mm 	1
H5	Plastic Cap 	4

### DISCLAIMER:

WHEN PROPERLY ASSEMBLED, THIS ITEM IS SAFE FOR INTENDED USE. SELLER IS NOT LIABLE FOR ANY DAMAGES RESULTING FROM ITEM BEING IMPROPERLY ASSEMBLED AFTER PURCHASE.



### Assembly Procedures:

Step 1. Assemble the Desk on a flat, soft surface such as a carpet or cloth to prevent scratching the finish. Attach Short Stretcher (P4) & Long Stretcher (P5) to the Short Frame Leg (P2) & Long Frame Leg (P3) as shown below.

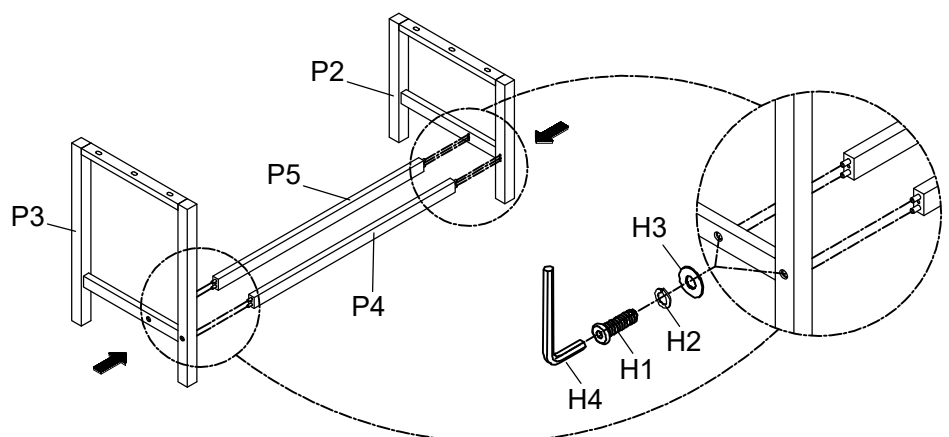
- (H1)x4 Bolts 
- (H2)x4 Lock Washer 
- (H3)x4 Flat Washer 



Step 2. Turn over the Table Top (P1) on a flat, soft surface such as a carpet or cloth to prevent scratching the finish. Attach the Base to the Table Top (P1) as shown below.

- (H1)x6 Bolts 
- (H2)x6 Lock Washer 
- (H3)x6 Flat Washer 

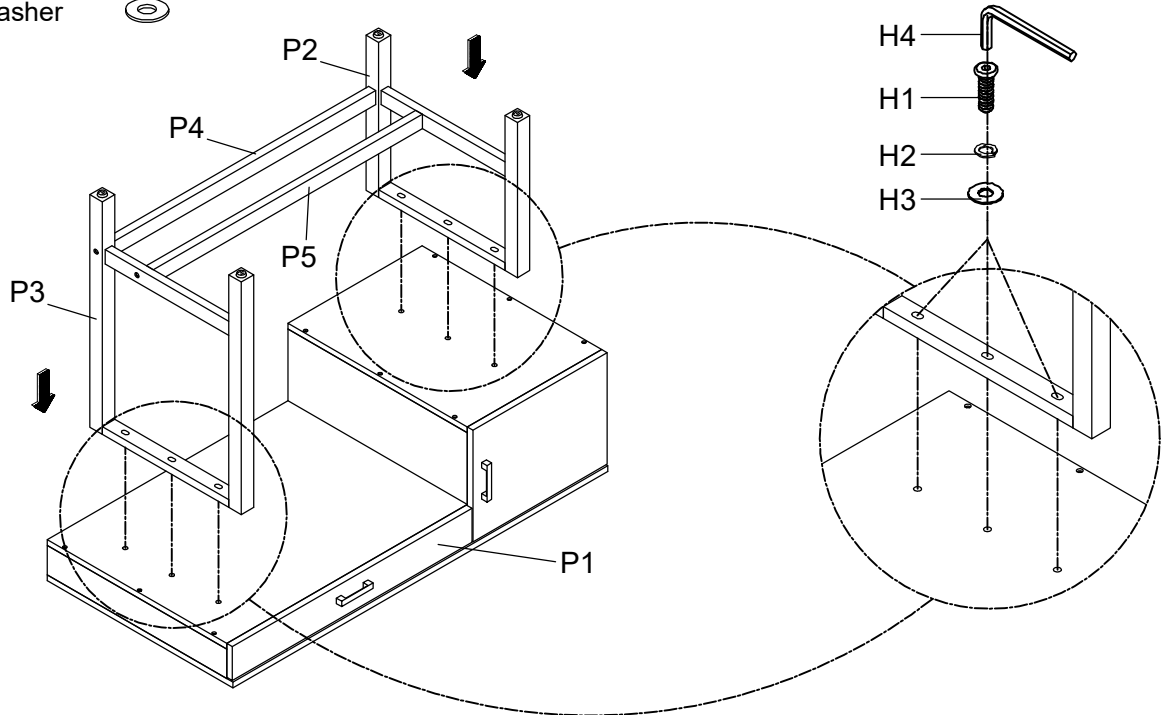

Step 3: Turn the Desk over and place it upright on a level surface. Insert the Plastic Cap (H5) to cover the Bolt holes as shown below. Assembly is complete.

- (H5)x4 Plastic Cap 

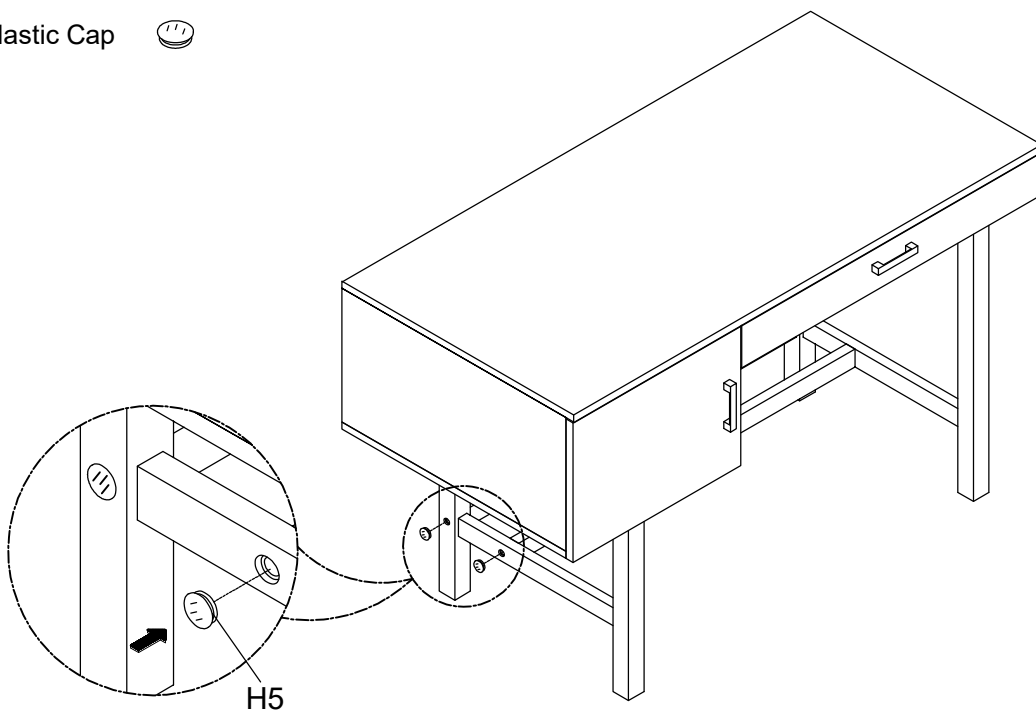

**ADDITIONAL NOTE ABOUT SAFETY:**  
BOLTS MAY LOOSEN DURING NORMAL EVERYDAY USE.  
THEY SHOULD BE INSPECTED AT LEAST EVERY 3 MONTHS AND RE-TIGHTENED AS NEEDED TO PREVENT DAMAGE OR INJURY, AND ENSURE STABILITY.

Thank you for your purchase