

ASSEMBLY INSTRUCTIONS

Description: Adela Writing Desk





Important safety instructions:

- Please read carefully all instructions before assembly.
- For your safety and ease, assembly by two or more adults is recommended.
- Keep instructions for future use.

Pre-assembly:

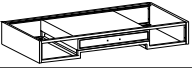
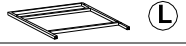

- Do not discard any content until assembly is complete to avoid accidentally discarding small parts or hardware.
- Take out all parts and hardware from box.

Parts List

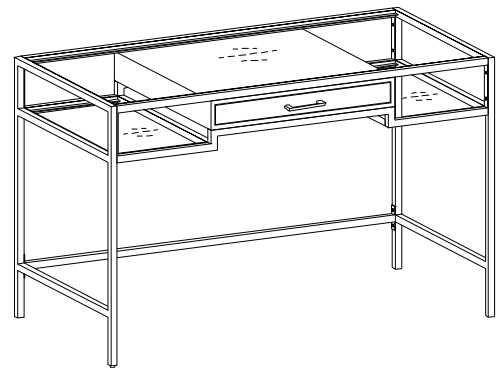
Item	Description		QTY
P1	Top Frame		1
P2	Left Side Frame		1
P3	Right Side Frame		1
P4	Stretcher		1
P5	Top Glass		1
P6	Shelf Glass		2



Hardware List

Item	Description		QTY
H1	Bolts $\varnothing 1/4'' \times 1/2''$		12
H2	Plastic Pad		14
H3	Allen Wrench 1/4"		1

DISCLAIMER:

WHEN PROPERLY ASSEMBLED, THIS ITEM IS SAFE FOR INTENDED USE. SELLER IS NOT LIABLE FOR ANY DAMAGES RESULTING FROM ITEM BEING IMPROPERLY ASSEMBLED AFTER PURCHASE.

Assembly Procedures:

Step 1. Assemble the desk on a flat, soft surface such as a carpet or cloth to prevent scratching the finish. Remove the protective plates on both sides of the top frame (P1) before installation, see below image 1.

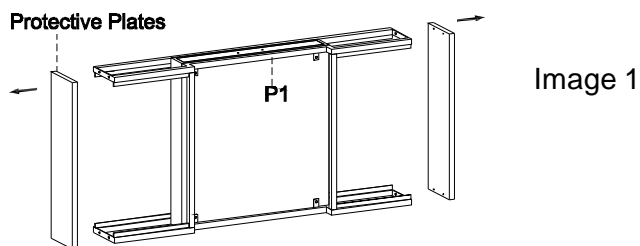

Step 2. Attach the left side frame (P2) and right side frame (P3) to the top frame (P1) and attach the stretcher (P4) to side frames as shown below image 2.

(H1)x12 Bolts $\varnothing 1/4'' \times 1/2''$



(H3)x1 Allen Wrench 1/4"

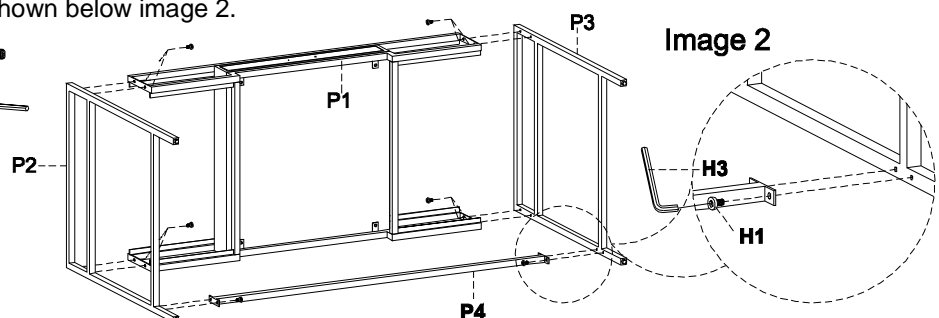

Step 3. 1). Securely tighten all bolts with Allen wrench(H3), make sure the bench is leveled and aligned properly. Turn the assembled desk to an upright position.
 2). Place the plastic pads (H2) on the top of desk frame, then gently place the shelf glass (P6) and top glass (P5) to the pads as shown on below image 3.

(H2)x14 Plastic Pad 

Image 3

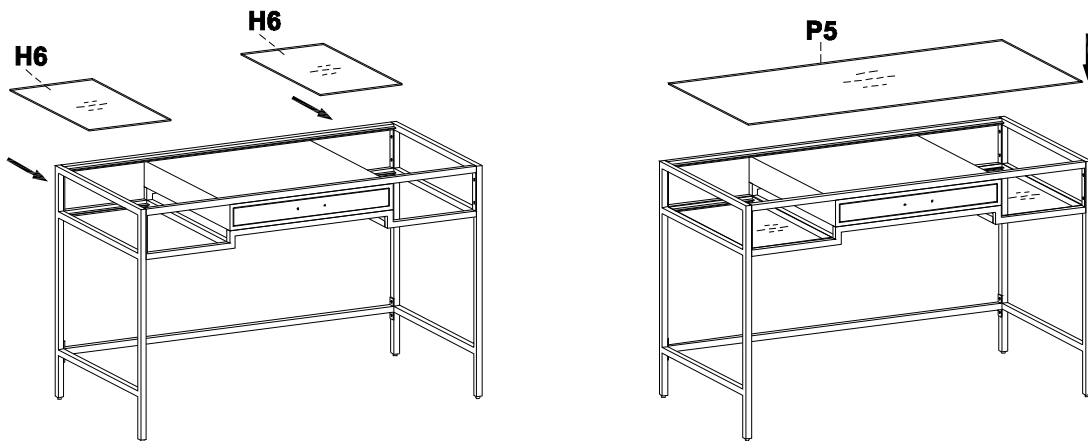
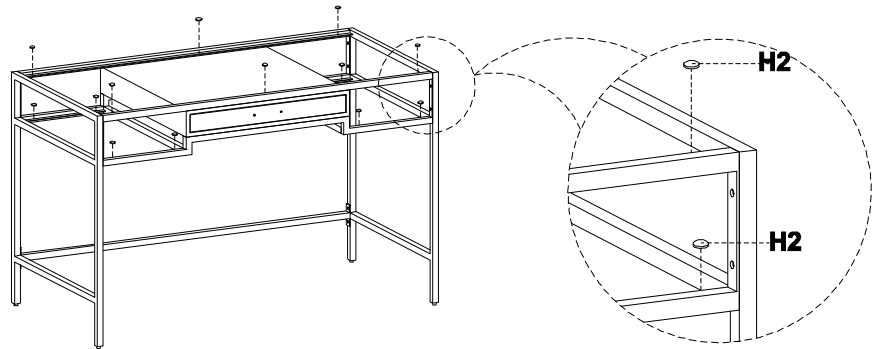

Step 4. 1) Remove the handles from the back of drawer front panel by unscrewing the bolts with screw driver (not provided).
 2) Reattach the handles to the front of drawer front panel using bolts as shown below.
 3) To level desk. If there is a gap between a leg and the floor, please adjust the adjustable leveler up or down under each leg. Assembly is complete. **Failure to follow these instructions may cause the bolts to misalign during assembly.**

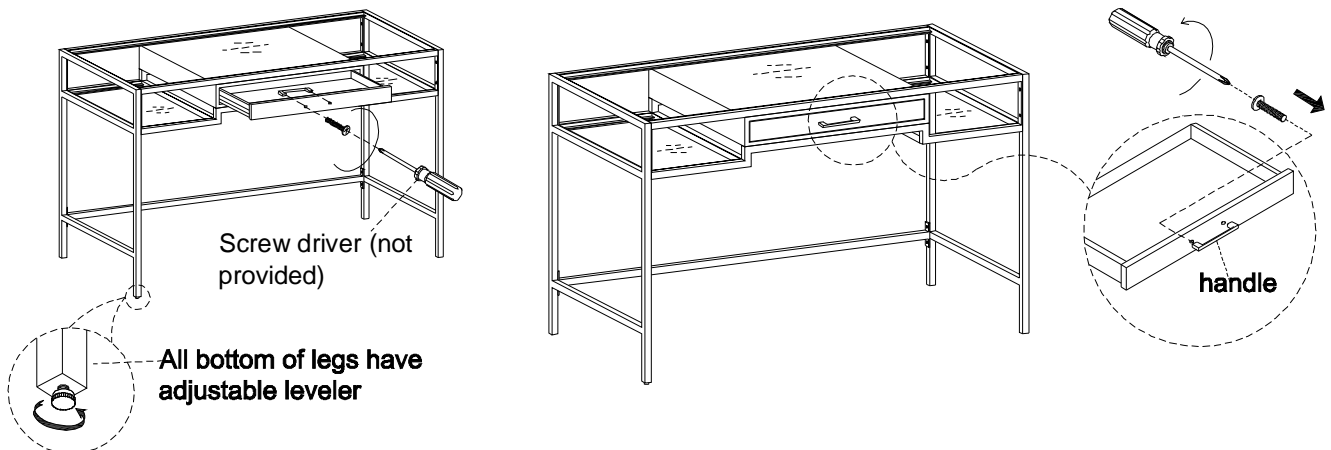

ADDITIONAL NOTE ABOUT SAFETY: BOLTS MAY LOOSEN DURING NORMAL EVERYDAY USE. THEY SHOULD BE PERIODICALLY INSPECTED AND RE-TIGHTENED TO PREVENT DAMAGE OR INJURY. ALWAYS CHECK TO ENSURE THAT ALL HARDWARE IS KEPT TIGHTENED.

Thank you for your purchase