

**Important safety instructions:**

- Please read carefully all instructions before assembling.
- For your safety and ease, assembly by two or more adults is recommended.
- Keep instructions for future use.

**Pre-assembly:**

- Do not discard any content until assembly is complete to avoid accidentally discarding small parts or hardware.
- Take out all parts and hardware from box.

**Parts List**

Item	Description	QTY
P1	Counter Stool Top	1
P2	Legs	2
P3	Support Bar	2
P4	Footrest	2

**Hardware List**

Item	Description	QTY
H1	ALLEN WRENCH 1/4"	1
H2	Bolts φ1/4*10mm	8
H3	ALLEN WRENCH 5/16"	1
H4	Spring washer φ5/16"	6
H5	Bolts φ5/16*18mm	6

**DISCLAIMER:**

WHEN PROPERLY ASSEMBLED, THIS ITEM IS SAFE FOR INTENDED USE. SELLER IS NOT LIABLE FOR ANY DAMAGES RESULTING FROM ITEM BEING IMPROPERLY ASSEMBLED AFTER PURCHASE.

**Assembly Procedures:**

Step 1. Assemble the counter stool on a flat, soft surface such as carpet or cloth to prevent scratching. Insert support bar (P3) and footrest (P4) to the legs (P2). Using allen wrench (H1) to tighten bolts (H2) as illustration below.

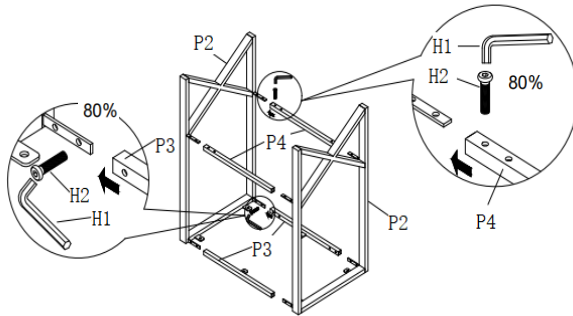

Step 2. Using spring washer (H4), bolts (H5), attach legs (P2) to counter stool top (P1). Tighten bolts (H5) with allen wrench (H3) as illustration below.

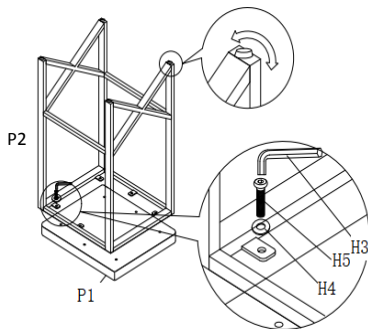

Step 3. Place counter stool upright on a level surface. Assembly is complete.

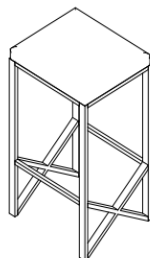

**ADDITIONAL NOTE ABOUT SAFETY: BOLTS MAY LOOSEN DURING NORMAL EVERYDAY USE. THEY SHOULD BE PERIODICALLY INSPECTED AND RE-TIGHTENED TO PREVENT DAMAGE OR INJURY. ALWAYS CHECK TO ENSURE THAT ALL HARDWARE IS KEPT TIGHTENED.**