

ASSEMBLY INSTRUCTIONS

Description: EVERLY CHAIR

Important safety instructions:

- Please read carefully all instructions before assembly.
- For your safety and ease, assembly by two or more adults is recommended.
- Keep instructions for future use.

Pre-assembly:

- Do not discard any content until assembly is complete to avoid accidentally discarding small parts or hardware.
- Take out all parts and hardware from box.

Parts List

Item	Description	QTY
P1	Chair Back	2
P2	Seat	2
P3	Front Legs	4

Hardware List

Item	Description	QTY
H1	Medium Bolts M6x70	8
H2	Long Bolts M6x90	8
H3	Short Bolts M6x40	4
H4	Flat Washer	20
H5	Spring Washer	20
H6	Allen Wrench	1

DISCLAIMER :
WHEN PROPERLY ASSEMBLED, THIS ITEM IS SAFE FOR INTENDED USE.
SELLER IS NOT LIABLE FOR ANY DAMAGES RESULTING FROM ITEM BEING IMPROPERLY ASSEMBLED AFTER PURCHASE.

Step 1 Assemble front legs

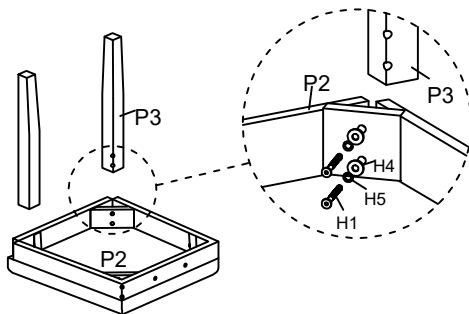

Step 2 Assemble chair back with seat on center hole. Do not fully tighten bolts.

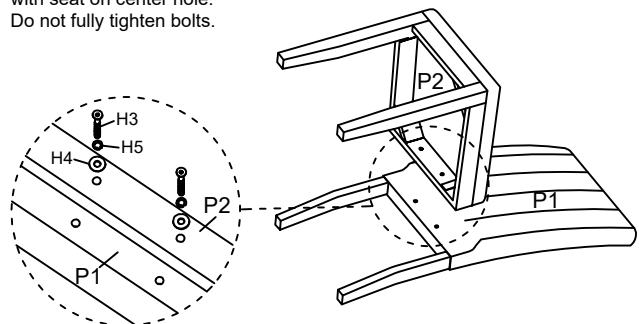

Step 3 1. Ensure the chair is level and all legs are assembled before fully tightening the bolts. 2. Assemble chair back and seat with the holes in the corners. Tighten all bolts.

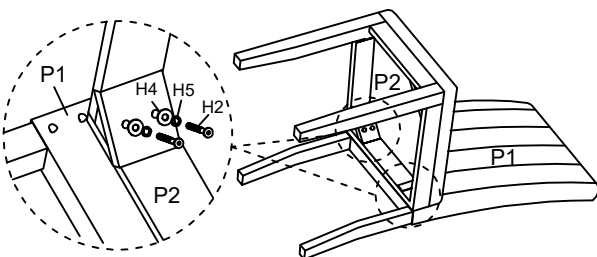

Assembly Complete

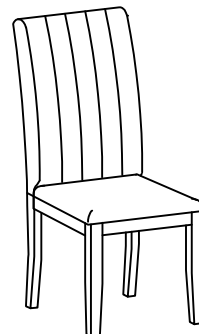

Please repeat for the second chair.

ADDITIONAL NOTE ABOUT SAFETY :
BOLTS MAY LOOSEN DURING NORMAL EVERYDAY USE.
THEY SHOULD BE INSPECTED AT LEAST EVERY 3 MONTHS AND RE-TIGHTENED AS NEEDED TO PREVENT DAMAGE OR INJURY AND ENSURE STABILITY.

Thank you for your purchase.