













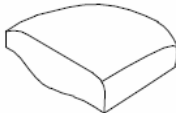

ASSEMBLY INSTRUCTION

LOT# 12317STPG ARNAU CHAIR

PARTS LIST							
PARTS#	PARTS NAME	DRAWING	QTY	PARTS#	PARTS NAME	DRAWING	QTY
A	FLAT WASHER 5/16"X 3/4"		9	K	FRONT LEG		2
B	LOCK WASHER 5/16"		9	L	LEFT ARM		1
C	BOLTS DIA 5/16"X3-1/2"		4				
D	BOLTS DIA 5/16"X2"		5	M	RIGHT ARM		1
E	BOLTS DIA 1/4"X1-3/4"		4				
F	FLAT WASHER 1/4"X 5/8"		4	N	SEAT FRAME		1
G	LOCK WASHER 1/4"		4				
H	WOOD SCREW		2				
I	ALLEN WRENCH 5/16"		1	O	CHAIR BACK		1
J	ALLEN WRENCH 1/4"		1				

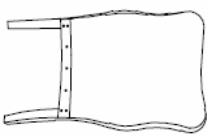
Note: Do Not tighten bolts until assembly is fully completed.

STEP 1.

Remove all parts from carton and separate them into part number groups as indicated on the part list. Place the chair back (O) on a smooth flat surface with the holes facing up. Loosely tighten all bolts until instructed to fully tighten at the end of step.

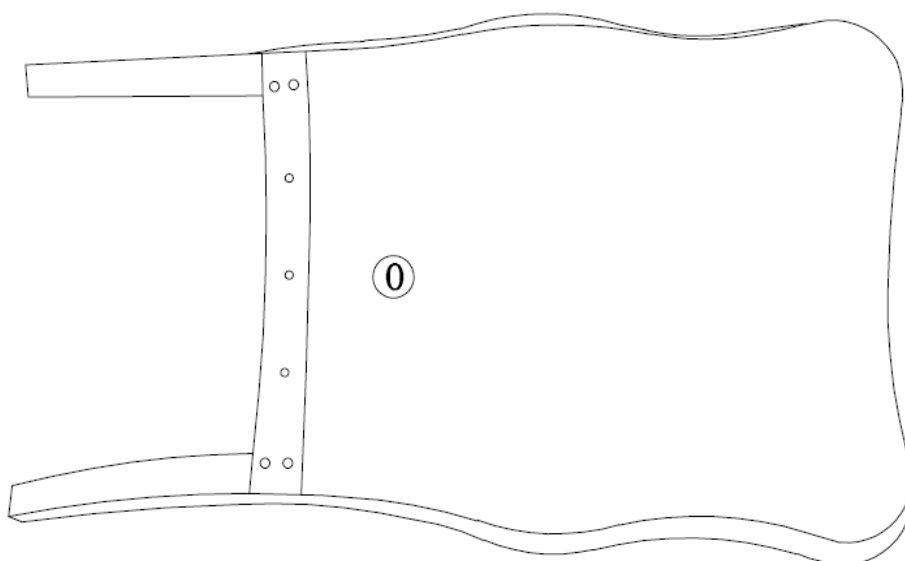

ASSEMBLY INSTRUCTION

LOT# 12317STPG ARNAU CHAIR

STEP 2.

Attach seat frame (N) to chair back (O). Insert flat washer (A) lock washer (B) and bolts (D) through center hole of back rail. Insert flat washer (A) lock washer (B) and bolts (C) through corner block to back leg. Use allen wrench (I) to secure bolts (C,D). Tighten slightly not fully.

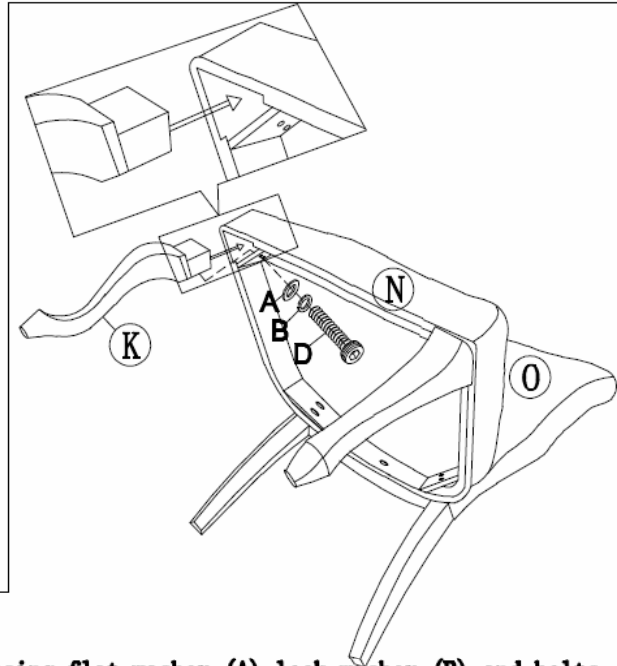
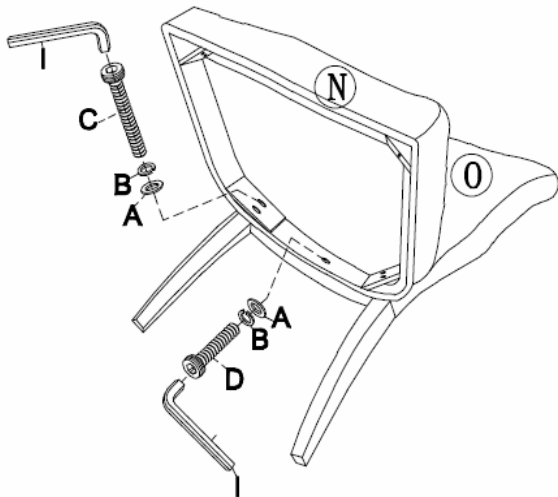

STEP 3.

Attach front leg (K) to seat frame (N) using flat washer (A) lock washer (B) and bolts (D). Tighten slightly not fully.

STEP 4.

Caution : Use of incorrect bolts in the section could result in damage to the arm. Attach the arm to the seat frame (N) with flat washer (F) lock washer (G) and bolts (E) using wrench (J). Secure the arm rest to chair back (O) with wood screw (H). Place chair upright on a level surface & tighten all bolts securely.

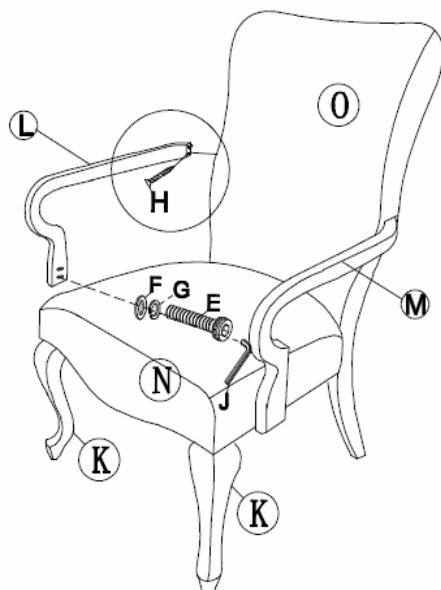

Warnings : Failure to observe these warnings can result in serious injury and/or product damage:

- * Never stand on the chair.
- * Never use the chair as a ladder.
- * Do not tip the chair when seated.
- * Periodically re-tighten all bolts.
- * Do not exceed 250lbs. (113.4kgs) weight limit on the chair.